

New Account Plan Check

Date: _____ Inspector: _____

Account: _____ Results from Old Dishmachine: _____

Address: _____ Water Heater Recover Rate: _____

Phone: _____ Fax: _____ Pre-rinse Condition: _____

Contact: _____ New Booster Requirements: _____

Installation Information: _____ Voltage: _____ Amps: _____ Phase: _____ KW: _____

Dishmachine Model: _____ Water Softener: _____ Hardness: _____

Date and Time of Install: _____ Door Width to Bring Dishmachine In: _____ Stairs: _____

Old Dishmachine: Leave: Store: Dispose: Table Condition: Broken: Leaking: Cut: No Lip:

Booster: _____ Instructions: _____

Electrical Power: _____ Circuit Bkr Size: _____ Wire Size: _____

Plumbing Size and Height on Drain: _____ For Conveyor Machine: _____

Racks per/Day: _____ Persons per/Day: _____ Circuit Bkr Size: _____ Wire Size: _____ Amps: _____

Single: Double: Undercounter: Corner: Voltage: 208v 240v III Phase I Phase

Table Layout: Movable Tables: _____ Vents 4x16" Pantlegs or Overhood (size _____ x _____)

Floor Sink Location: _____ Location of Table Sinks from Dishmachine: _____

Scrap Trap Location: _____

Disposal Location: _____

NOTE: HT25, ADC66, and some ADC44 machines require a Neutral wire in addition to supply wires.

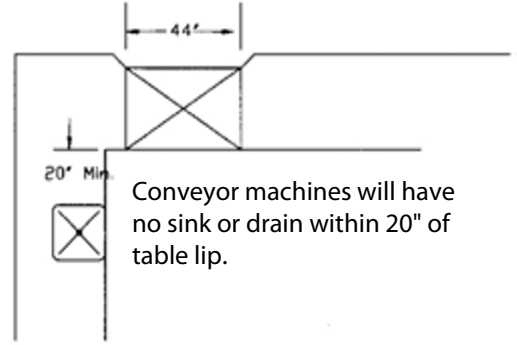
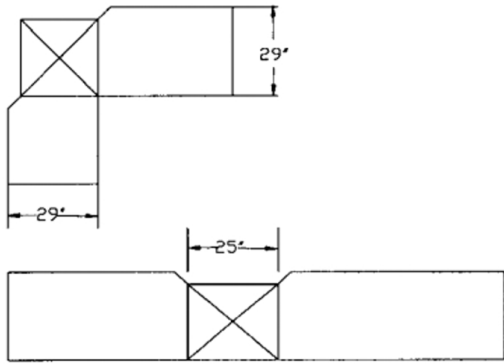

Comments