

American Dish Service

INSTALLATION INSTRUCTIONS

Model JDS12 (T) or (R) “Muffler” Booster

(T) 12kW, 240v, 3-ph, (R) 12kW, 208v, 3-ph

Manufactured by Hubbell Electric Heater Company for use on American Dish Service dishwashers
If you have questions, call 800-922-2178 or visit our website at www.AmericanDish.com



DANGER

The electrical power supplied to this machine is an imminent hazard that will result in severe injury or death if not avoided. When working in the control box or on electrical parts, always disconnect power and tag-out before servicing. Replace cover to control box and other protective covers when finished servicing this equipment.



CAUTION

READ Manufacturer's Manual before Using this Product. For your safety read and observe all cautions shown throughout these instructions. While performing installations described in this booklet, wear approved Personal Protective Equipment, including Safety Eye-Wear.



Showing the JDS12 Booster

The following text reprinted by permission from Hubbell Electric Heater Company's Operating and Maintenance Manual for JDS12T (240v) and JDS12R (208v).



WARNING/CAUTION

1. Tank is to be completely filled with water and all air is to be vented before energizing.
2. Due to the rigors of transportation, all connections should be checked for tightness before heater is placed in operation
3. The refractory material in the heating elements may absorb some moisture during transit, periods of storage, or when subjected to a humid environment. This moisture absorption may result in a cold insulation resistance of less than twenty (20) megohms. If this heater has been subjected to the above condition, each heating element must be checked for insulation resistance before energizing.
4. Keep away from live electrical circuits. Do not perform any maintenance, make any adjustments, or replace any components inside the control panel with the high voltage power supply turned on. Under certain circumstances, dangerous potentials may exist even when the power supply is off. To avoid casualties, always turn the power supply safety switch to off, turn the charge or ground the circuit before performing any maintenance or adjustment procedure.
5. The unit is designed to operate at atmospheric pressure only. Do not install any valves in the outlet line and ensure that the outlet line is open to atmosphere.

Specifications

Model	Volts	Ph	Power (kW)	Amps	Recovery (GPH) @ 40F Rise	Min. Feed Breaker or Fuse Size	Power Feed Wire Size (75C Cu (THHN))	Conduit Size
JDS12T	208	1	9	43.3	92.4	50	8	3/4"
	220	1	10.1	45.8	103.4	50	8	3/4"
	230	1	11	47.9	113	50	8	3/4"
	240	1	12	50	123	60	6	3/4"
	208	3	9	25	92.4	30	10	1/2"
	220	3	10.1	26.5	103.4	30	10	1/2"
	230	3	11	27.7	113	30	10	1/2"
	240	3	12	28.9	123	30	10	1/2"
JDS12R	208	1	12	57.7	123	60	6	3/4"
	208	3	12	33.3	123	40	8	3/4"

Power feed wire sizing is based on using 75° C Cu THHN wire with feeder branch protection rated at 100% for a non-continuous load.

INSTALLATION AND START-UP



WARNING/CAUTION

Do not turn on the electric power supply to this equipment until heater is completely filled with water and all air has been released. **If the heater is NOT filled with water when the power is turned on, the heating elements will burn out.**

The unit is designed to operate at atmospheric pressure only. Do not install any valves in the outlet line and ensure that the outlet line is open to atmosphere.

Installation or service of this unit requires ability equal to that of a licensed tradesman in the field.

The installation must conform to these instructions and any local authority having jurisdiction. Grounding and electrical wiring connected to the unit must also conform to the latest version of the National Electric Code NFPA-70.

PIPING INSTALLATION

Connect the warm water inlet (lower connection) and hot water outlet (upper connection) to the ½" FNPT connections at the back of the unit. Teflon tape should be used on all NPT Threaded pipe connections.

FILLING THE HEATER

Open the valve to the booster water inlet and allow the heater and piping system to completely fill, as indicated by a steady flow of water through the dishwasher rinse nozzles.

NOTE: Flush the tank at full flow for 10 minutes prior to putting into service.

ELECTRICAL INSTALLATION

Enter the enclosure through the factory cut KO's with properly sized feeder leads, See Specifications. Single-phase installations require two (2) leads. Three-phase installations are intended for use with a 3-wire delta system plus ground. No neutral is required. For a 4-wire plus ground system, install 3 legs of power plus the ground and terminate the neutral leg.

Install these power leads into the box lugs on the magnetic contactor, as required.

Connect incoming ground wire to ground lug supplied.

All other electrical connections are made at the factory; therefore, no other electrical connections are necessary.

Check all connections, including factory connections for tightness.

OPTIONAL FIELD CONVERSION FROM SINGLE TO THREE PHASE OR VICE-VERSA (See Drawing on page 9)

For 3-phase wiring the elements should be wired as follows: One RED wire and one BLUE wire to terminal 1 of the contactor, one RED wire and one YELLOW wire to terminal 2 of the contactor, and one Blue wire and one YELLOW wire to terminal 3 of the contactor.

For single phase wiring the elements should be wired as follows: one RED wire, one BLUE wire, and one YELLOW wire each to terminals 1 and 3 of the contactor.

FINAL CHECKS

Check all connections for tightness.

After the water is heated for the first time, monitor the water temperature as described in Annual Inspection.

OPERATION AND SCHEDULED MAINTENANCE



WARNING/CAUTION

Before performing any maintenance procedure, make certain the power supply is turned OFF and cannot accidentally be turned on.

OPERATION

The water heater is automatic in its operation. It will maintain a full tank of water at the temperature setting of the controller. To adjust the temperature controller setpoint, turn the temperature adjustment screw clockwise to increase the temperature and counter-clockwise to decrease temperature. The water heater should not be turned on without first making sure that the tank is full of water and that all air has been released.

ANNUAL INSPECTION

1. Monitor water temperature

Let water heater completely heat to a designated temperature setting.

After controller satisfies (when the magnetic contactor clicks off), draw water from as close as possible heater outlet and measure the temperature.

Compare the water temperature of outlet water to the desired temperature setting. Adjust the temperature controller as required.

If desired temperature cannot be achieved, see the Troubleshooting section.

2. Inspect elements for leakage as follows:

Shut off power supply and remove enclosure cover.

Visually inspect around heating element for evidence of leaks.

CAUTION: The area around the heating element may be hot.

3. Scale and mineral build-up on heating elements is a normal condition. It is recommended that the heating element be removed for examination and if scaled, should be cleaned. In an area of known hard or poor water conditions, the elements may need to be checked more frequently. This will improve the efficiency of the heater and increase the element life.

4. Check for loose electrical connections. Tighten as necessary.

TROUBLESHOOTING

Contactors Care

A chattering or humming from the contactor is due to dust or debris on the contact points that prevents the contactor from making proper contact. The debris can be removed by utilizing a can of antistatic cleaning and dusting spray (pressurized air) and spraying through the side of the contactor to remove the debris.

General Troubleshooting

Symptom	Probable Cause	Corrective Action
Water reaches setpoint temperature but does not last through the entire dishwasher cycle or water at the dishwasher is not the proper temperature.	Low incoming water temperature.	Incoming water temperature must be adequate for the heater size. Increase the incoming water temperature.
	Incoming water temperature is dropping.	Primary water supply is not adequate to continually provide correct temperature in sufficient quantities. Increase the supply of primary warm water.
	Incorrect voltage.	Voltage available at the water heater must be correct to achieve proper recovery. Verify voltage on all phases.
	One or more elements are not energizing.	Verify that each element is drawing the correct amperage. Replace elements as required.
	Temperature setpoint too low	Adjust the temperature setpoint.
Water heater does not heat at all	Main supply circuit breaker tripped	Check and /or reset the circuit breaker.
	Magnetic contactor does not energize	See the "Control Troubleshooting" section.
	Unit in Hi-limit	Allow unit to cool and press the hi-limit reset.
	Element Failure	Verify correct wiring from the heating elements to the magnetic contactor. Disconnect the wires from each element and verify that the resistance (ohms) value for each element is correct. Ohms reading should be between 15.8 and 17.5 for 240v elements and 18.3 and 20.2 for 208v elements. Replace elements as required.

CONTROL TROUBLESHOOTING

Verify correct wiring

With power off at the main breaker and the rocker switch set to the ON position, check for continuity between the center and top terminals on both sides of the rocker switch. If there is no continuity on either side, replace the switch.

After allowing the unit to cool and verifying that the unit does not operate after pressing the hi-limit reset, with power off at the main breaker check for continuity between the two terminals of the hi-limit switch. If there is no continuity, replace the hi-limit switch.

With power off at the main breaker and the temperature controller set at maximum, check for continuity between the two terminals of the temperature controller. If there is no continuity, replace the temperature controller.

With unit calling for power (power on and temperature setpoint above the water temperature in the vessel), check for voltage (208 to 240 VAC) between the two magnetic contactor coil terminals. If voltage is present and magnetic contactor does not energize, replace the magnetic contactor.

SERVICING AND REPLACEMENT OF PARTS



WARNING/CAUTION

Before servicing or replacing any part, make sure to turn the power supply to the unit OFF.

Heating Element

1. Disconnect power from unit.
2. Shut off incoming water supply and drain water from tank.
3. Disconnect the wires from the heating element terminals.
4. Unscrew element (15/16" hex).
5. Install new o-ring gasket and install new heating element.
6. Rewire element.
7. Fill tank and check around element for any leaks.

Magnetic Contactor

1. Disconnect power from unit.
2. Disconnect line, load, and control wires to contactor.
3. Loosen nuts and remove contactor.
4. Replace with new contactor using reverse procedure.

Rocker Switch

1. Disconnect power from unit.
2. Disconnect wires to rocker switch.
3. Hold in mounting tabs and remove the rocker switch from the enclosure.
4. Install new rocker switch using reverse procedure.

Hi-Limit Switch

1. Disconnect power from unit.
2. Disconnect wires to hi-limit switch.
3. Loosen nut on the top of the enclosure under the reset cap and remove hi-limit switch and bulb and capillary assembly.
4. Install new hi-limit switch using reverse procedure.

Control Thermostat

1. Disconnect power from unit.
2. Disconnect wires to temperature controller.
3. Loosen mounting screws and remove thermostat and bulb and capillary assembly.
4. Install new temperature controller using reverse procedure.

For further information on the Hubbell booster, call 203 378 2659, fax 203 378 3593, or visit <http://www.hubbellheaters.com>.

AS INSTALLED ON ADS DISHMACHINES

IMPORTANT: The dishmachine must be setup using its minimum water consumption. Excessive water use by the dishmachine will cause lower delivered temperatures from the booster. See “Tuning Section” in the dishmachine installation manual.

Plumbing connections for atmospheric (non-pressure vessel) booster.



Flex hose connections (only hand tighten hose fittings)



Connection from bkr to heater ~ from heater to air-gap

Electrical connection from building's power source will enter the box at the cutout shown below.
IT IS RECOMMENDED THAT THIS EQUIPMENT BE INSTALLED USING A NEW CIRCUIT BREAKER.



Pre-cut hole for conduit and power wires



Connection point for wires on right-side of contactor



Showing hi-limit switch at left of contactor



Hi-limit reset button

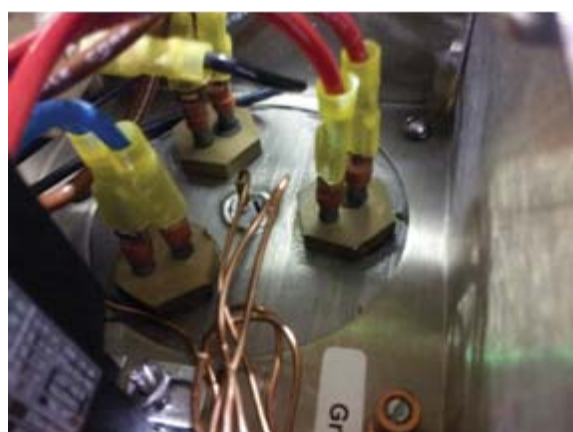

The three heater elements located behind hi-limit



Under-frame mounting



In-frame mounted



Shown on AF-ES in-frame mounting position

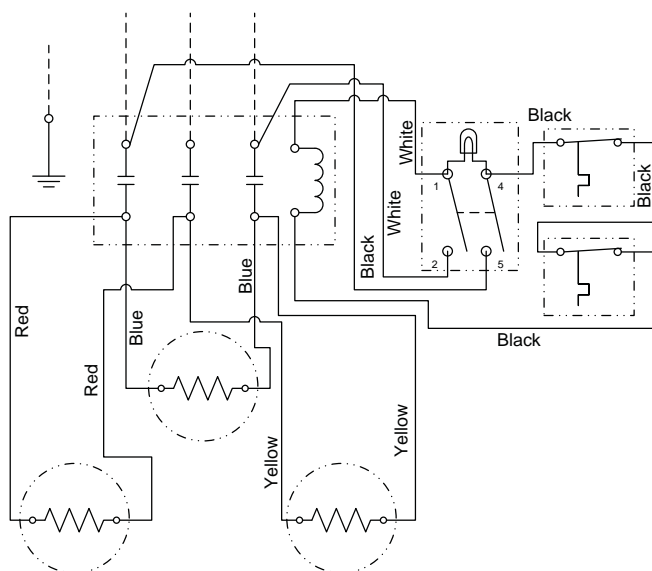

3-Phase

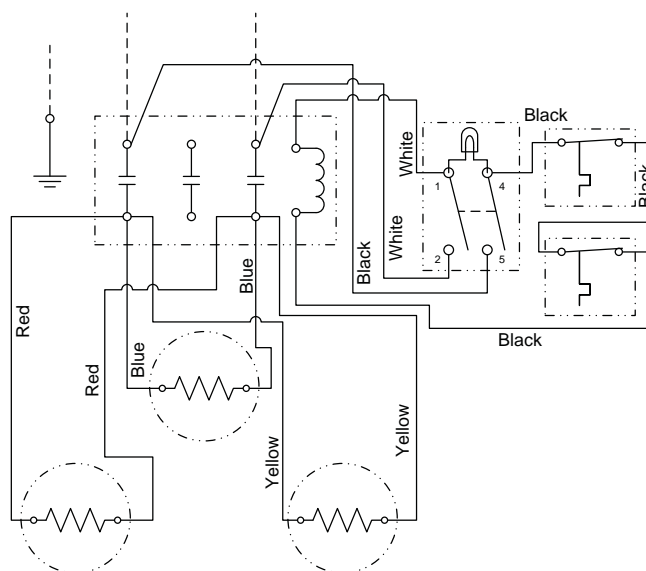

Single Phase

Optional Field Conversion from Single to Three Phase or Vice-Versa

1. For 3-phase wiring the elements should be wired as follows: One RED wire and one BLUE wire to terminal 1 of the contactor, One RED wire and one YELLOW wire to terminal 2 of the contactor, and One BLUE wire and one YELLOW wire to terminal 3 of the contactor.
2. For single phase wiring the elements should be wired as follows: One RED wire, one BLUE wire, and one YELLOW wire each to terminals 1 and 3 of the contactor.