

AFB Bakery Series by

The *Economical Answer* to Tall Warewashing Needs

AFB Bakery Dishwasher

LOW ENERGY
TIME-SAVER
RELIABLE



Sheet Pans require a Special
Stainless Steel Dishrack for Proper
Washing.



- Available in either 90, 120, or 150 second time cycle
- Holds Standard 20" x 20" Racks
- High Pressure, 1.5 HP Pump
- Built-In chemical dispensing

At American Dish Service, Quality People, Designs, and Products have been the foundations of our organization for *60 years*.

www.americandish.com

900 Blake Street Edwardsville, KS 66111-3820

American Dish Service
Manufacturers of Ware Washing Equipment

Toll Free

Phone

Fax

(800) 922-2178 (913) 422-3700 (913) 422-6630

AFB Bakery

Available in Corner and Pass-Through Models

27 1/2" Door Opening with Safety Interlock



A complete warewashing center in only 121" of floor space. the soil dishtable incorporates three 20" x 20" x 14" deep sinks.

(Longer Lengths Available)

- **Quality & Reliability**
- **Effective Washing & Sanitizing of Bakery Trays and Pots & Pans**
- **Built In Scrap Accumulator**

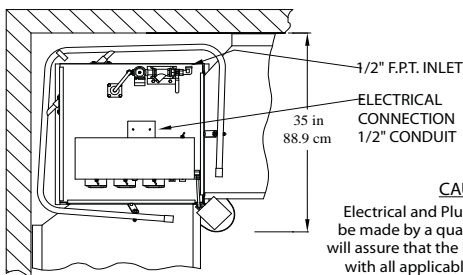

TOP VIEW
CORNER APPLICATION

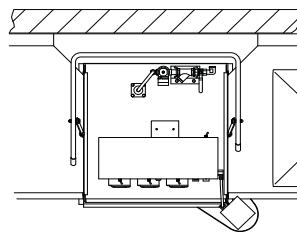

TOP VIEW
IN-LINE APPLICATION

CAUTION:
Electrical and Plumbing connections must be made by a qualified Service Person who will assure that the installation is in compliance with all applicable federal, state, and local Health, Electrical, Plumbing, and Safety Codes.



American Dish Service

WWW.AMERICANDISH.COM

AFB Series

	AFB		
RATED CAPACITY (Racks/Hour)	37	25	12
WASH TIME (Sec.)	45	60	75
RINSE TIME (Sec.)	30	45	60
DWELL (Sec.)	15	15	15
TOTAL CYCLE TIME (Sec.)	90	120	150

WATER TEMPERATURE (Supply)	130° F Min. 54.4° C Min.
WATER CONSUMPTION	2.5 Gal's Per Cycle 9.5 Liters Per Cycle
MOTOR	1.5 HP 1.125 KW
ELECTRICAL RATINGS	115 Volts Single Phase
Connect to Supply Source using 10-12 AWG copper wires on a clean circuit. Circuit Protection: 20 Amp Circuit Breaker or Fuse with a 20 AMP Rating.	

RACK SIZE	19 3/4" x 19 3/4"
DOOR CLEARANCE	50.2 cm x 50.2 cm 27 1/2" x 20 1/2"
WATER INLET	69.9 cm x 52.1 cm
DRAIN (Scrap Trap)	1/2" F.P.T.
HEIGHT (Door Open)	2" Pipe 94"
HEIGHT (Door Closed)	238.8 cm
HEIGHT (Table to Table)	78 1/2"
WIDTH (Overall)	199.4 cm
WIDTH (Table to Table)	33 1/2"
DEPTH (Overall)	85.1 cm
DEPTH (Table to Table)	25"
SHIPPING WEIGHT	63.5 cm 35"
SHIPPING VOLUME (36"x 36"x 86")	88.9 cm 330 lb. 133.8 kg. 64.5 cu. ft. 1.83 cu meters

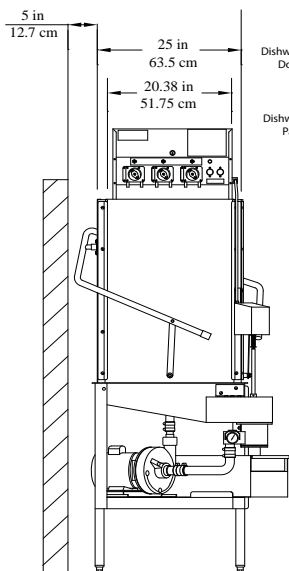

SIDE VIEW
CORNER APPLICATION

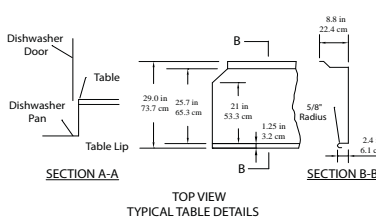

TOP VIEW
TYPICAL TABLE DETAILS

NOTE:
All dimensions listed have a tolerance of + or - 1/4" unless otherwise noted.

NOTE:
Manufacturer reserves the right to modify these Specifications in compliance with regulatory agencies and manufacturing expediency.

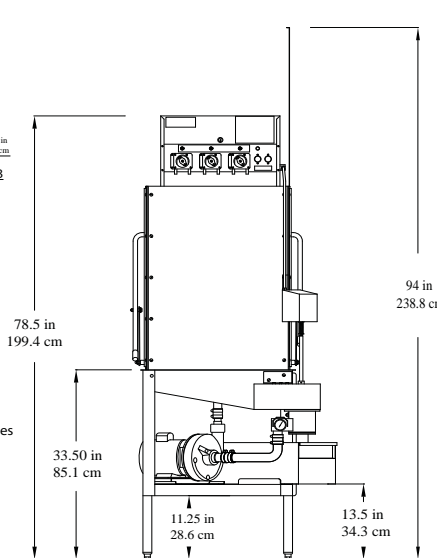

FRONT VIEW
IN-LINE APPLICATION

Effective: 08/2017

© 08/2017 American Dish Service

ADS has built a strong history based on Customer Service, Quality and Reliability. A Commitment to Excellence is the driving force behind American Dish Service.

900 Blake Street Edwardsville, KS 66111-3820 **Toll Free** (800) 922-2178 **Phone** (913) 422-3700 **Fax** (913) 422-6630