

# ET Series by

## MULTI-USE UNDERCOUNTER DISHWASHERS

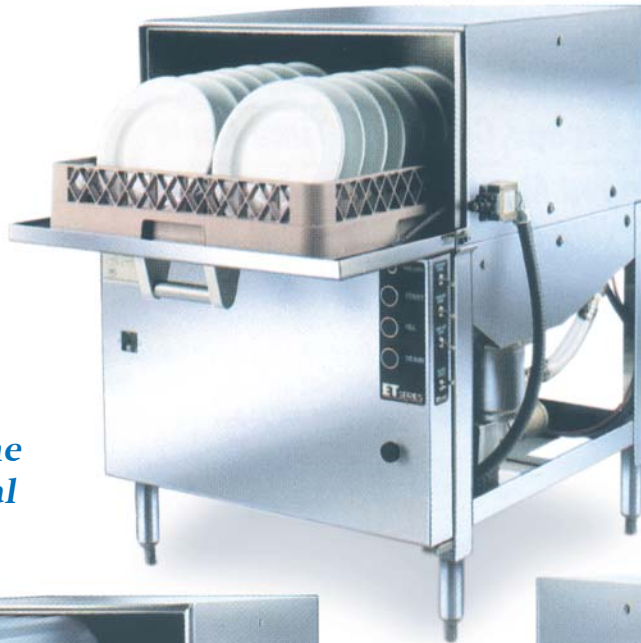

*Perfect for Restaurants,  
Delicatessens & Fast  
Food Operations*

*An Industrial  
Design Machine  
for Commercial  
Application*

*FINALLY, an undercounter  
that offers kitchenware results,  
in a glass washing machine*

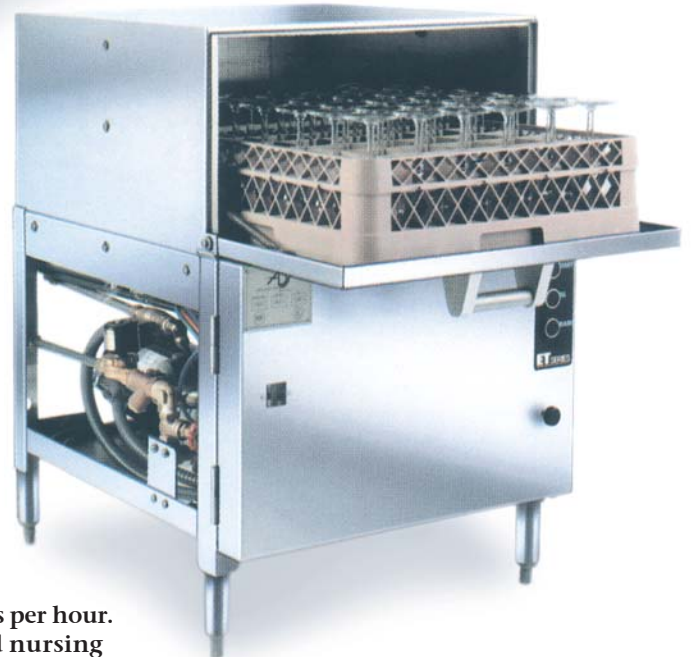
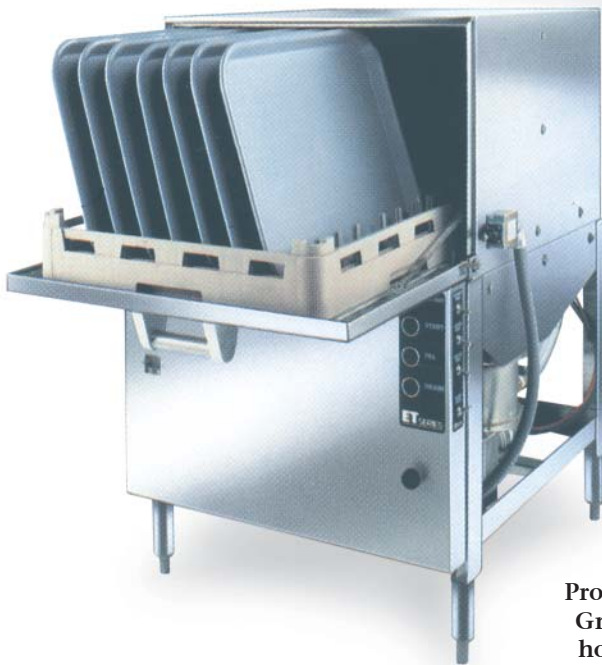

Process over 200 trays per hour.  
Great for small bed nursing  
homes and day care facilities

**When space demands a small dishmachine, don't sacrifice quality or results.  
*Ask for one of the ET-AF UNDERCOUNTERS.***

At American Dish Service, Quality People,  
Designs, and Products have been the foundations  
of our organization for over 45 years.

[www.americandish.com](http://www.americandish.com)

  
**American Dish Service**  
Manufacturers of Ware Washing Equipment

900 Blake Street Edwardsville, KS 66111-3820 **Toll Free** (800) 922-2178 **Phone** (913) 422-3700 **Fax** (913) 422-6630

# ET Series

MULTI-USE UNDERCOUNTER DISHWASHERS

**ET... The Dishmachine of choice, when space is a concern. You will NEVER AGAIN have to sacrifice production or results.**

- 1 1/2 HP Wash and Rinse Pump
- Prime Switches
- Automatic Chemical Feed
- 90 Second Complete Time Cycle
- Hinged Mounted Panel for Easy Service Access

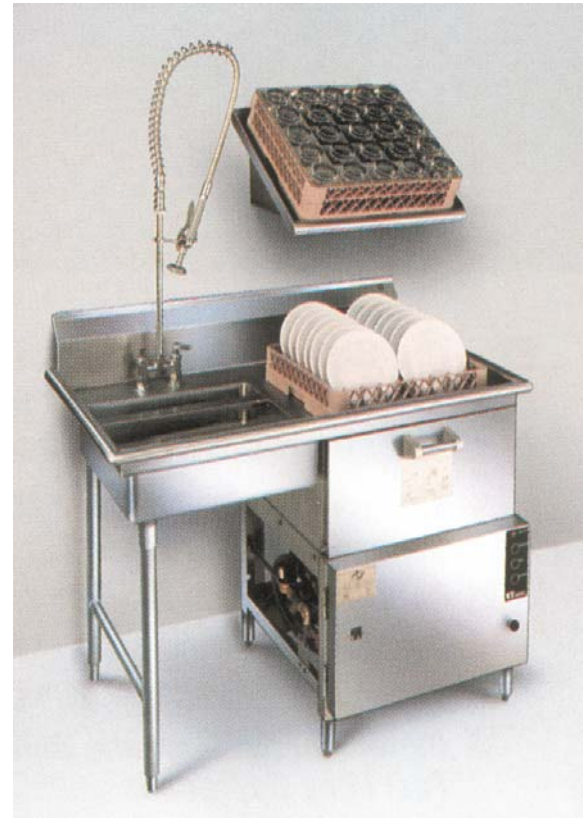

Operate a free standing complete warewashing center in only 48" of space. To do this, combine our ET-AF Undercounter with our stainless steel table package.

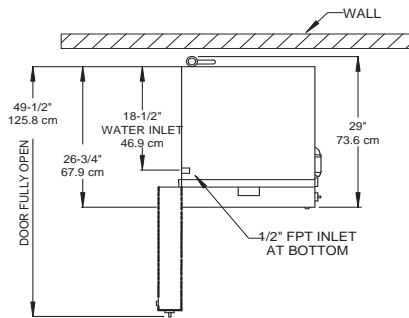

TOP VIEW

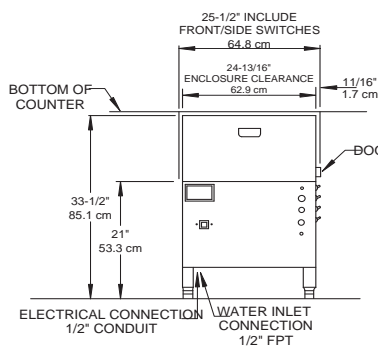

FRONT VIEW

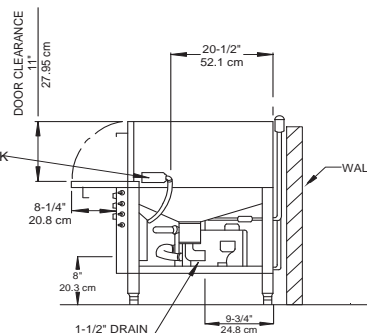

SIDE VIEW

**CAUTION:**  
Electrical and plumbing connections must be made by a qualified Service Person who will comply with all available federal, state, and local Health, Electrical, Plumbing, and Safety codes.

\*Manufacturer reserves the right to modify these specifications in compliance with regulatory agencies and manufacturing expediency.

**NOTE:**  
All dimensions listed have a tolerance of + or - 1/8" unless otherwise noted.

**ADS**  
**American Dish Service**  
Manufacturers of Ware Washing Equipment  
WWW.AMERICANDISH.COM

## ET SERIES SPECIFICATIONS

	FAMILY MODELS
	ET-AF ET-A ET-AH
NSF RATED CAPACITY (Racks/Hr.)	30 24 20
WASH TIME (Sec.)	45 60 75
RINSE TIME (Sec.)	30 45 60
DWELL (Sec.)	15 15 15
TOTAL CYCLE TIME (Sec.)	90 120 150
WATER TEMPERATURE-SUPPLY WATER	(NSF) 120 F Min. 49 C Min.
WATER CONSUMPTION (NSF RATED)	1.7 Gal's Per Cycle 6.4 Lit's Per Cycle
MOTOR RATING (PUMP)	1.5 HP
DRAIN MOTOR RATING	1.125 KW
ELECTRICAL RATINGS (NEC)	115 Vac, 20amp brkr, 50/60Hz, 1Phase
Connect to Supply Source using 10-12 AWG copper wires using non-time delay fuse of 20 amp rating or 20 amp circuit breaker.	
RACK SIZE	19.75" x 19.75" 50.2 cm x 50.2 cm
DOOR CLEARANCE	"M" Series: 11" x 22.25" (27.9cm x 56.5cm) "3" Series: 14" x 22.25" (35.8cm x 57cm)
WATER INLET	1/2" FPT
DRAIN SIZE	3/4" I.D. Hose by 60" Long
HEIGHT OF STANDARD ET	Min 33.5"-Max 34.5" 85.1 to 87.6 cm
HEIGHT OF ET-AF-3	Min 36.5"-Max 37.5" 92.7 to 95.2 cm
WIDTH (Overall)	25.5" 64.8 cm
DEPTH (Overall)	29" 73.6 cm
SHIPPING WEIGHT	"M" Series: 250 Pounds (113.4 kg) "3" Series: 258 Pounds (117.0 kg)
SHIPPING DIMENSIONS	"M" Series: 36"L x 36"W x 41"H "3" Series: 36"L x 36"W x 44"H

Copyright 4/16

Effective: 4/16

Toll Free Phone Fax  
900 Blake Street Edwardsville, KS 66111-3820 (800) 922-2178 (913) 422-3700 (913) 422-6630