

AFB Series

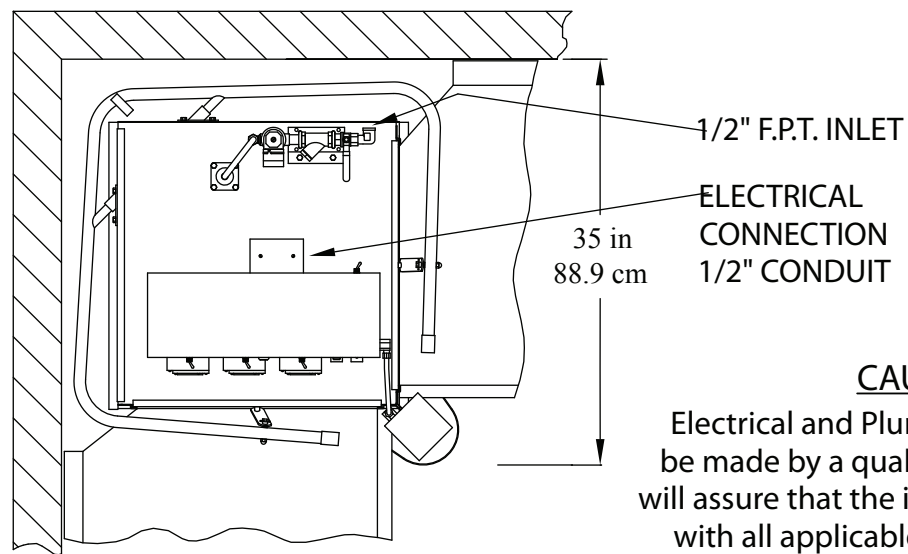

TOP VIEW
CORNER APPLICATION

CAUTION:
Electrical and Plumbing connections must be made by a qualified Service Person who will assure that the installation is in compliance with all applicable federal, state, and local Health, Electrical, Plumbing, and Safety Codes.

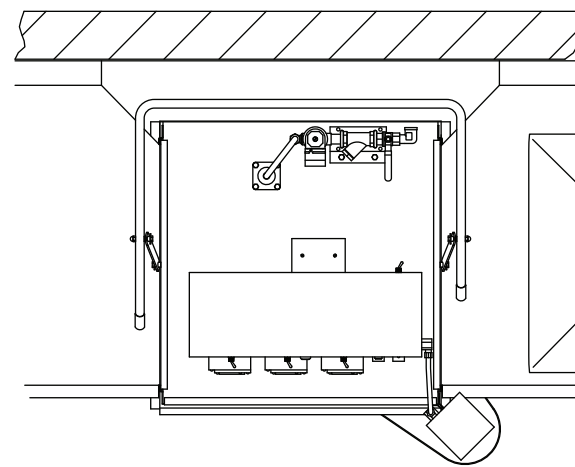

TOP VIEW
IN-LINE APPLICATION

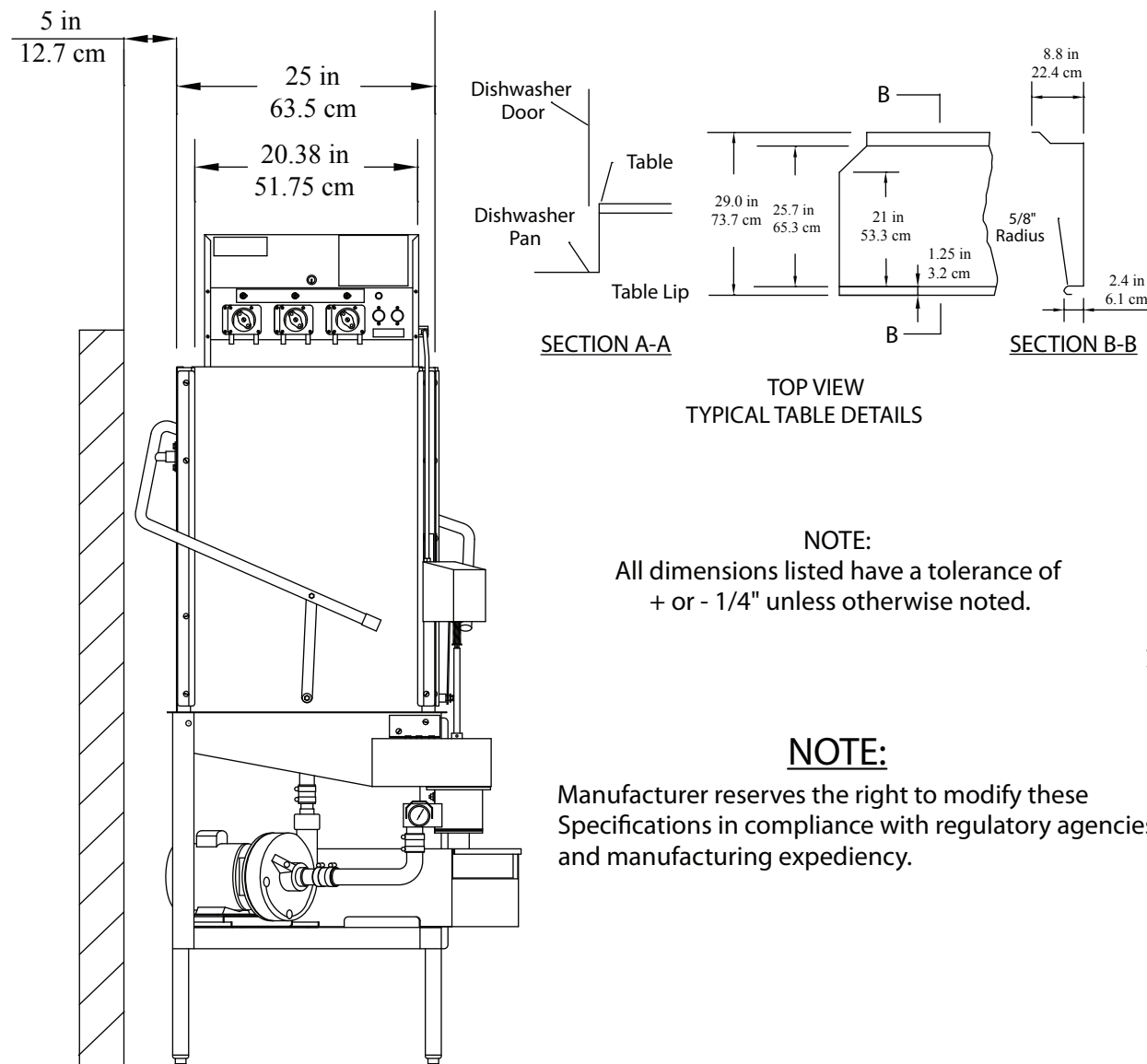

SIDE VIEW
CORNER APPLICATION

SECTION A-A

TOP VIEW
TYPICAL TABLE DETAILS

SECTION B-B

NOTE:
All dimensions listed have a tolerance of + or - 1/4" unless otherwise noted.

NOTE:
Manufacturer reserves the right to modify these Specifications in compliance with regulatory agencies and manufacturing expediency.

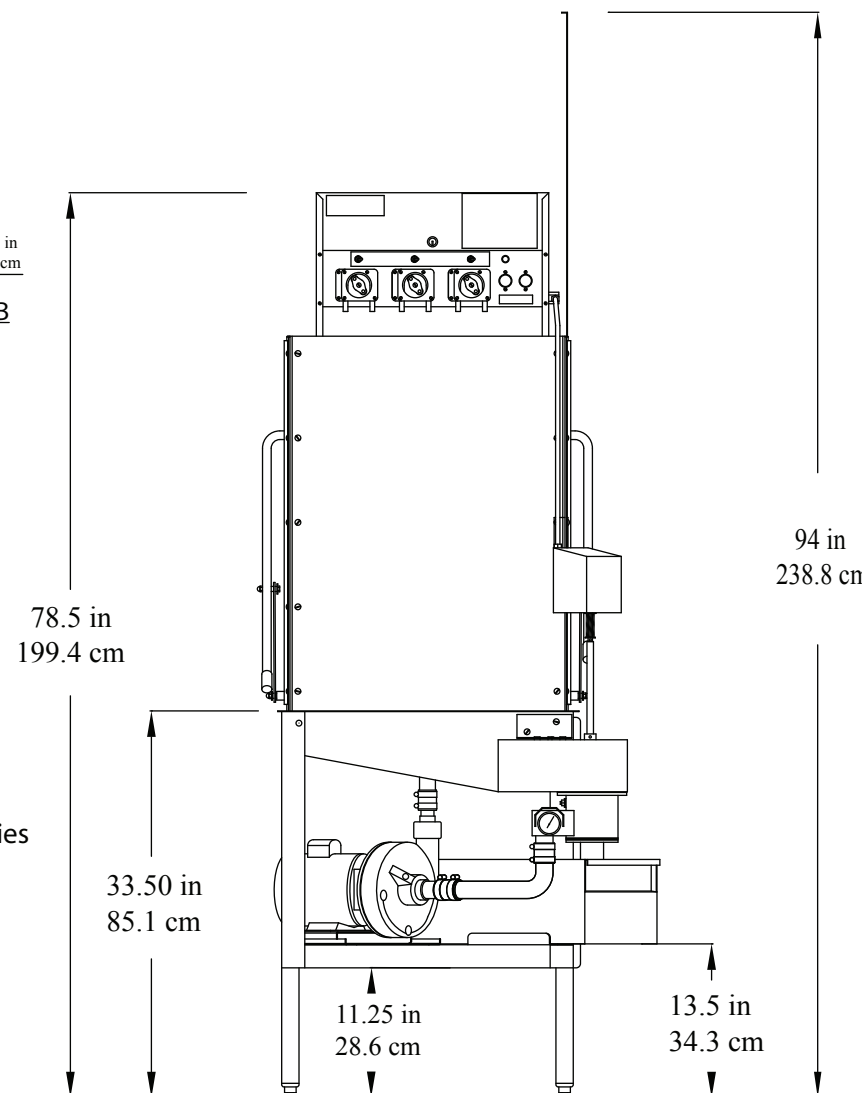

FRONT VIEW
IN-LINE APPLICATION

	AFB		
RATED CAPACITY (Racks/Hour)	37	25	12
WASH TIME (Sec.)	45	60	75
RINSE TIME (Sec.)	30	45	60
DWELL (Sec.)	15	15	15
TOTAL CYCLE TIME (Sec.)	90	120	150

WATER TEMPERATURE (Supply)	130° F Min. 54.4° C Min.
WATER CONSUMPTION	2.5 Gal's Per Cycle 9.5 Liters Per Cycle
MOTOR	1.5 HP 1.125 KW
ELECTRICAL RATINGS	115 Volts Single Phase
Connect to Supply Source using 10-12 AWG copper wires on a clean circuit. Circuit Protection: 20 Amp Circuit Breaker or Fuse with a 20 AMP Rating.	

RACK SIZE	19 3/4" x 19 3/4" 50.2 cm x 50.2 cm
DOOR CLEARANCE	27 1/2" x 20 1/2" 69.9 cm x 52.1 cm
WATER INLET	1/2" F.P.T.
DRAIN (Scrap Trap)	2" Pipe
HEIGHT (Door Open)	94" 238.8 cm
HEIGHT (Door Closed)	78 1/2" 199.4 cm
WIDTH (Overall)	33 1/2" 85.1 cm
WIDTH (Table to Table)	25" 63.5 cm
DEPTH (Overall)	35" 88.9 cm
SHIPPING WEIGHT	330 lb. 133.8 kg.
SHIPPING VOLUME (36"x 36"x 86")	64.5 cu. ft. 1.83 cu meters