

TOP VIEW

CAUTION:

Electrical and plumbing connections must be made by a qualified Service Person who will comply with all available federal, state, and local Health, Electrical, Plumbing, and Safety codes.

*Manufacturer reserves the right to modify these specifications in compliance with regulatory agencies and manufacturing expediency.

NOTE:

All dimensions listed have a tolerance of + or - 1/8" unless otherwise noted.



American Dish Service

Manufacturers of Ware Washing Equipment

WWW.AMERICANDISH.COM

ET SERIES with PUMPED DRAIN and HEAT SPECIFICATIONS

	FAMILY MODELS		
	ET-AF	ET-A	ET-AH
NSF RATED CAPACITY (Racks/Hr.)	30	24	20
WASH TIME (Sec.)	45	60	75
RINSE TIME (Sec.)	30	45	60
DWELL (Sec.)	15	15	15
TOTAL CYCLE TIME (Sec.)	90	120	150
WATER TEMPERATURE-SUPPLY WATER	(NSF) 120 F Min. 49 C Min.		
WATER CONSUMPTION (NSF RATED)	1.7 Gal's Per Cycle 6.4 Lit's Per Cycle		
MOTOR RATING (PUMP)	1.5 HP		
DRAIN MOTOR RATING	1.125 KW		
SUSTAINER HEATER	1/20 HP (.037 KW) 1/2 KW		
ELECTRICAL RATINGS (NEC)	115 Vac, 20amp brkr, 50/60Hz, 1Phase		
Connect to Supply Source using 10-12 AWG copper wires using non-time delay fuse of 20 amp rating or 20 amp circuit breaker.			
RACK SIZE	19.75" x 19.75" 50.2 cm x 50.2 cm		
DOOR CLEARANCE	"M" Series: 11" x 22.25"(27.9cm x 56.5cm) "3" Series: 14" x 22.25"(35.8cm x 57cm)		
WATER INLET	1/2" FPT		
DRAIN SIZE	3/4" I.D. Hose by 60" Long		
PUMP-OUT HEIGHT (Maximum)	15"		
HEIGHT OF STANDARD ET	Min 33.5"-Max 34.5" 85.1 to 87.6 cm		
HEIGHT OF ET-AF-3	Min 36.5"-Max 37.5" 92.7 to 95.2 cm		
WIDTH (Overall)	25.5" 64.8 cm		
DEPTH (Overall)	29" 73.6 cm		
SHIPPING WEIGHT	"M" Series: 270 Pounds (122.5 kg) "3" Series: 274 Pounds (124.3 kg)		
SHIPPING DIMENSIONS	"M" Series: 36"L x 36"W x 41"H "3" Series: 36"L x 36"W x 44"H		

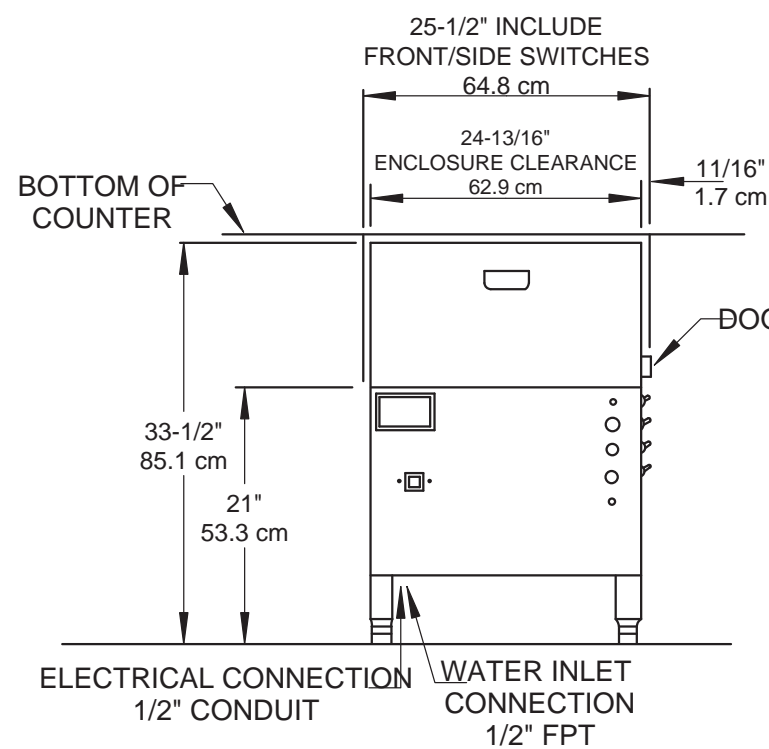

FRONT VIEW

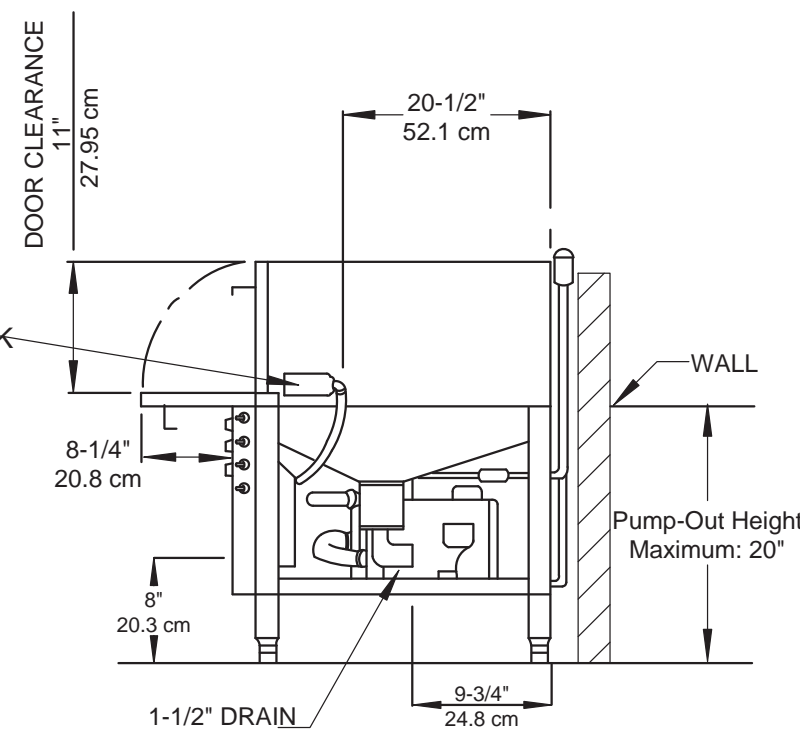

SIDE VIEW