

Model 5AG-ES



High Capacity "Green" Machine

Energy Star® rated: less than 1 gallon per rack

STANDARD FEATURES

- Double duty model - double your production
- Large 20.5" door opening - washes larger ware
- Stainless steel air gap - no leaking back flow preventers
- Dual screens protect pump for cleaner wash arms
- Washes 74 racks per hour with two powerful 1 HP pumps



Optional Pan Rack

Wash sheet pans horizontally



© American Dish Service

900 Blake Street | Edwardsville, Kansas, 66111
Phone: 913.422.3700 | Toll-Free: 800.922.2178 | Fax: 913.422.6630
orders@americandish.com | americandish.com

For detailed specifications, go to
www.americandish.com

Model 5AG-ES

High Capacity "Green" Machine

Standard Features

- Cleans 74 racks per hour
- Water consumption of less than 1 gallon per rack
- Top mount controls with auto start
- Two high capacity 1 HP pumps
- Door safety switch & external prime switches
- Delime switch located in the control panel



Get the same great quality & results you expect from ADS while using less water, energy & chemicals

Model 5AG-ES Specifications

U.S. REGISTERED PATENTS

Model 5AG-ES

Rated Capacity (Racks/Hr.)	74	56	46
Wash Time (Sec.)	50	60	75
Rinse Time (Sec.)	30	45	60
Dwell (Sec.)	15	15	15
Total Cycle Time (Sec.)	90	120	150

Water Tank Capacity (Miin) 1.75 Gal. (6.74 Liter)
 Water Temperature (Supply) 120° F Min. (49° C Min)
 Water Consumption (Per Cycle) 1.78 Gal. (6.74 Liter)
 Motor (2) 1.0 HP (0.75 Kw)
 Electrical Ratings 115 Volts, 18 AMP (Single Phase)

Connect to two Supply Sources using 12 AWG copper wires. Circuit Protection: 20 AMP Circuit Breaker or Fuse with a 20 AMP Rating. **OR**

Connect to Supply Source using 10 AWG copper wires suitable for at least 167° F (75° C). Circuit Protection: 30 AMP Circuit Breaker or Fuse with a 30 AQMP Rating.

Rack Size 19.75" x 19.75" (50.2 cm x 50.2 cm)
 Door Clearance 20.5" x 21" (52 cm x 53 cm)
 Water Inlet 0.75" FPT
 Drain (Scrap Trap) 2.0" Pipe
 Height (Door Open) 79.875" (202.9 cm)
 Height (Door Closed) 71.25" (180.9 cm)
 Width (Overall) 49" (124.5 cm)
 Depth (Overall) 34" (86.4 cm)
 Shipping Weight 446 lb. (202.3 kg)
 Shipping Dimensions 60" L x 36" W x 78" H
 (152.4 cm x 91.4 cm x 198.1 cm)

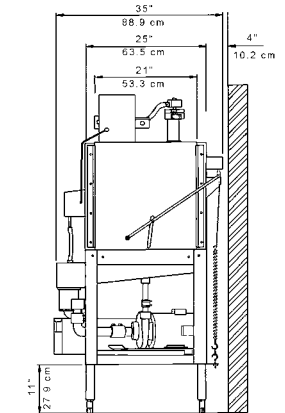
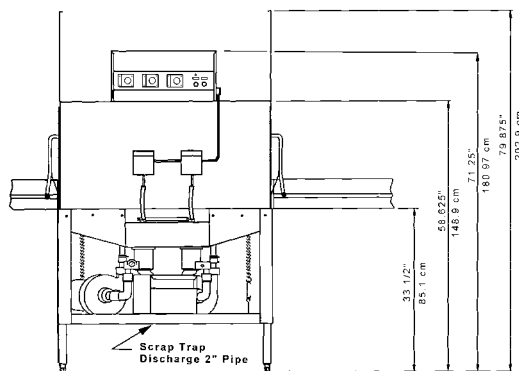
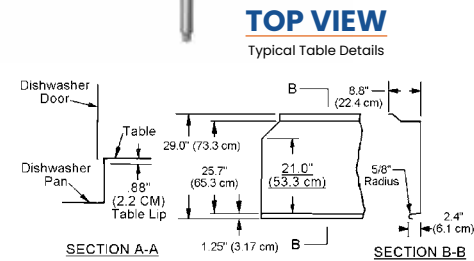
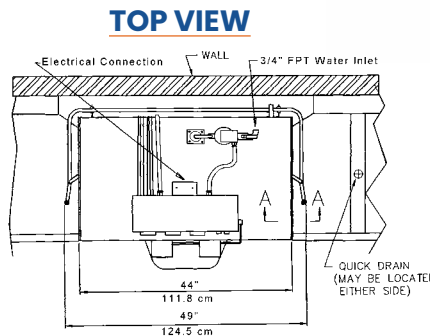

FRONT VIEW

SIDE VIEW

CAUTION:

Electrical and Plumbing connections must be made by a qualified Service Person who will comply with all available federal, state, and local Health, Electrical, Plumbing, and Safety Codes.

Note:

Manufacturer reserves the right to modify these specifications in compliance with regulatory agencies and manufacturing expediency.

Effective 2/2023

Warning: Cancer and Reproductive Harm – www.P65Warnings.ca.gov



American Dish Service™
 Manufacturers of Ware Washing Equipment



© American Dish Service

900 Blake Street | Edwardsville, Kansas, 66111
 913.422.3700 | Toll-Free: 800.922.2178 | Fax: 913.422.6630
orders@americandish.com | americandish.com